



SupplyWorks®

A Home Depot Company

Lighting
1-120

Electrical
121-214

Safety Products
215-254

Security
255-352

Hardware
353-388

Paint Supplies
389-412

Adhesives
Sealants & Patching
413-430

Tools
431-478

Ground &
Pool Supplies
479-512

Cleaning &
Janitorial Products
513-710

Food Service
711-728

Packaging &
Office Supplies
729-742

Hospitality
743-752

Appliances
753-776

HVAC
777-926

Plumbing
927-1216



Smarter Maintenance Solutions

supplyworks.com



Bobrick Washroom Equipment BOBRICK CLASSIC
TOILET SEAT COVER DISPENSER SURF
Priced Each
Item #: **BOBB-221**



Renown 8 in. Series Mechanical Black Paper Towel
Dispenser
Priced Each
Item #: **REN05173-WB**



Renown 3-Roll For OptiCore Black Toilet Paper
Dispenser
Priced Each
Item #: **REN05161-WB**



Appeal 1 | Hand Soap Dispenser Black, (15-Case)
Priced Each
Item #: **APP17104**



Unbranded Bobrick Surface-Mounted Sanitary Napkin
Disposal
Priced Each
Item #: **BOBB-270**



Tork Mini Mechanical Hand Towel Dispenser
Priced Each
Item #: **BWP774828**

REN05161-WB

HIGH-CAPACITY 3-ROLL TISSUE DISPENSER

Features:

- High-capacity alleviates washroom run out and saves maintenance time
- Accommodates Renown tissue product with OptiCore[®] technology
- Translucent cover allows service staff to see at-a-glance when it's time to refill
- Unique design ensures each tissue roll is completely used before advancing to next

Description:

The Renown 3-roll tissue dispenser is designed for high-capacity controlled-use dispensing of OptiCore[®] tissue products. When one roll of tissue is used, simply turn the dial to advance to the next roll. The OptiCore[®] technology ensures the maximum use of each roll in the dispenser to save maintenance time and costs. The Renown 3-roll is ADA Title III compliant when installed according to ADA guidelines. This sleek, contemporary dispenser also features a locking cover to prevent product pilferage and waste.

SPECIFICATIONS	
Color:	Black Translucent
Size (WxHxD in.):	14 1/8 x 14 9/16 x 6 5/16
Dispenser Weight:	3.6 lbs.
Case Quantity:	1
Case Cube:	0.81
Approx. Case Weight:	4 lbs.



3-Roll Bath Tissue Dispenser

DISPENSER FEATURES

The 3-Roll bath tissue dispensing system is designed to minimize maintenance and maximize cost savings for high-traffic areas. With its revolving design and our patented OptiCore® tissue, the 3-Roll ensures that a roll is completely depleted before the dispenser will advance to the next roll, eliminating waste. Capacity for three full rolls of tissue allows for longer periods between maintenance. The 3-Roll features a locking cover to prevent product pilferage.

- Accommodates patented OptiCore® bath tissue
- Provides maximum use of each roll before advancing to the next saving waste
- High-capacity dispensing



The 3-Roll tissue dispenser is ADA Title III compliant when installed according to the ADA Standards for Accessible Design. Paper is easily dispensed with one hand, with less than 5 lbs. of force and without tight grasping, pinching or twisting of the wrist.

Dispenser Weight: 3.6 lbs.

Dimensions:

14 1/8" x 14 9/16" x 6 5/16"

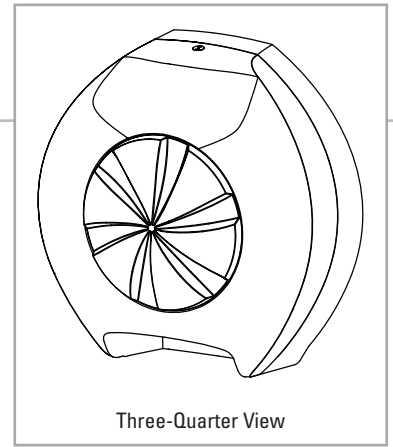

Three-Quarter View

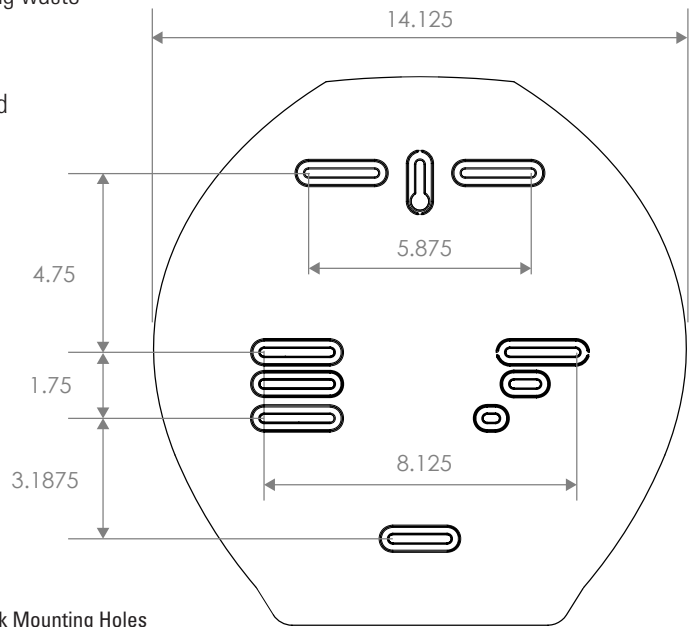

Back Mounting Holes

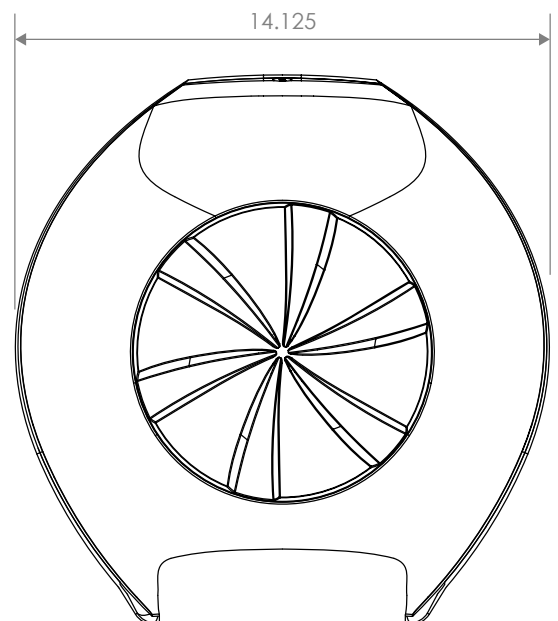
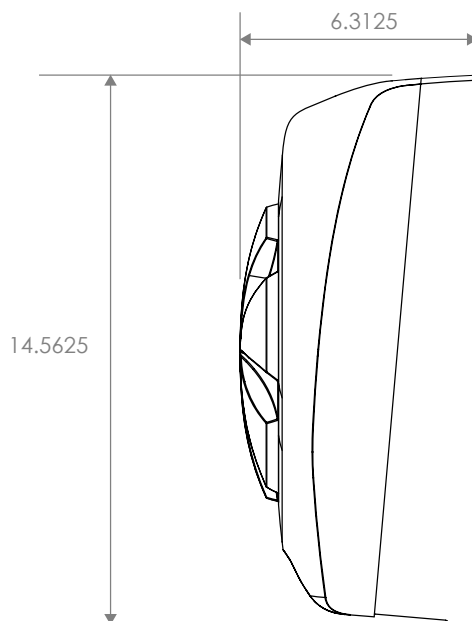



REN05173-WB
REN05174-WB



MECHANICAL HANDS-FREE ROLL TOWEL DISPENSER

Description:

Lasting solution for high-traffic areas. It's a dispenser you don't need to worry about – guaranteed to run well over hundreds of thousands of hand dries, saving you time, money, and hassle over its lifespan. Dispensing individual towels, it helps eliminate cross-contamination in busy areas.

Features:

- Performs consistently up to 360,000+ hand dries
- Dispenses 10" towel to control use and waste
- Virtually jam- and hassle-free
- Quick to load and service



SPECIFICATIONS

	8 INCH	7.5 INCH
Models:	REN05173-WB (USN: 3582735)	REN05174-WB (USN: 3582736)
Color:	Black Translucent	Black Translucent
Size (W" x H" x D"):	12.32 x 15.95 x 9.32	12.32 x 15.95 x 9.32
Dispenser Weight:	6.9 lbs.	6.9 lbs.
Case Qty:	1	1
Case Cube:	1.569	1.569
Approx. Case Weight:	8.8 lbs.	8.8 lbs.



Tork Mini Mechanical Hand Towel Roll Dispenser



Article	774828
Material	Plastic
System	H86 - Mini mechanical hand towel system
Height	12.5 in
Width	11.8 in
Depth	7.5 in
Color	Black

The Tork Mini Mechanical Hand Towel Roll Dispenser is ideal for environments where space is limited. Designed to fit tight spaces previously reserved for folded towels, the Tork Mini Mechanical Dispenser provides the operational benefits of a larger roll towel dispenser in a compact and attractive design. Dispenses and cuts a single 11-inch towel is ready and waiting for the next patron. Accommodates a variety of 8 inch controlled roll towels.

www.torkusa.com

- Fits tight spaces, like those between cabinets and countertops, at just over 12 inches high.
- Increases placement options with reversible cover that can be installed to open from the left or right.
- Saves maintenance time with at-a-glance refill monitoring through translucent cover.
- Prevents pilferage with locking cover.

Shipping data

	Consumer unit	Transport unit	Pallet
SCC	-	10073286644951	7322540922615
Items	1	1	0
Consumer units	-	1	0
Height	-	12.6 in	101 in
Width	-	7.8 in	39 in
Length	-	12.8 in	46 in
Volume	-	0.7 ft3	105 ft3
Net weight	-	5.6 lb	-
Gross weight	-	6.3 lb	-
Packing material	Box	Carton	-

Refill Options

Tork Advanced Hand Towel Roll 8634540

Tork Universal Hand Towel Roll 8621400

Alternative products



5510282



461102



552028

Contact

Essity Professional Hygiene North America LLC

Cira Centre, Suite 2600
2929 Arch Street
Philadelphia, PA 19104

Phone: (866-722-8675)



Antibacterial Foaming Hand Wash

Product Information Sheet



Description/Specification: Antibacterial foam hand wash, with Triclosan, is pleasantly perfumed and mild for frequent use. Cartridges are ultrasonically sealed, non-vented, and fully recyclable (HDPE Type 2). Formulated for one dose (0.7 mL) application.

Usage: Suitable for use in general industry, schools, and office washroom areas.

Method of Use: Apply foam to dry hands, spread well and rinse thoroughly with clean, running water.

	Feature	Benefit
Improves Health & Safety	Hygienic	The unique patented pump and cartridge are ultrasonically sealed and designed to prevent air ingress into the cartridge minimizing the risk of external contamination.
	Mild Formula	Uses skin conditioners to improve hydration and prevent drying of skin to encourage frequent use.
	Effective	A high-quality antibacterial formula eliminates 99.99% of germs and bacteria providing effective protection.
	Dispensers	Dispensers with BioCote™ protection are guaranteed for life and come in white or black with usage instructions to encourage hand washing best practice.
Environment	Green Seal Certified®	Green Seal provides customers with assurance that the products meet stringent standards of environmental leadership.
	Saves Water	Instant foam lather can be applied direct to dry hands before rinsing, saving approximately 45% of water consumption.
	Recyclable Packaging	All cartridge components and packaging are recyclable while formulations are biodegradable.
Reduces Cost	No Wastage	The cartridge collapses during normal use to ensure full evacuation of product.
	Highly Economical	Only one dose, 0.7 mL, is required to provide effective skin cleansing.



Antibacterial Foaming Hand Wash

Technical Data

Ingredients:

Active Ingredient: Triclosan, 0.30%
Inactive Ingredients: Water, Sodium Laureth Sulfate, Propylene Glycol, PPG-24-Glycereth-24, Cocamidopropyl Betaine, Tetrasodium EDTA, 2-Bromo-2-nitropropane-1,3-diol, Fragrance, Citric Acid, Green 5 (CI 61570), Yellow 5 (CI 19140)

Handling Instructions: Avoid contact with eyes. In case of contact with eyes, rinse immediately with plenty of water (for at least 10 minutes) and seek medical advice, if condition persists.

Shelf Life: This product has an expiration date of 3 years from the date of manufacture.

Regulatory Compliance: This product is manufactured and labeled in compliance with the Federal Food, Drug, and Cosmetic Act.

Product Testing

Test Type	Comment
Time Kill Efficacy	Conforms to the US FDA Tentative Final Monograph for Healthcare Antiseptic Drug Products with efficacy of 99.99% after a 30-second exposure period. Contact Deb for complete report.

Pack Size and Dispenser

Item No.	USN No.	Description	Case QTY
APP17101-04	102667	1L Antibacterial Foaming Hand Wash	4/CS
APP17105	102671	1L White Foaming Soap Dispenser	1/CS
APP17104	102670	1L Black Foaming Soap Dispenser	1/CS





Technical Data

ClassicSeries® SURFACE-MOUNTED SEAT-COVER DISPENSER

B-221

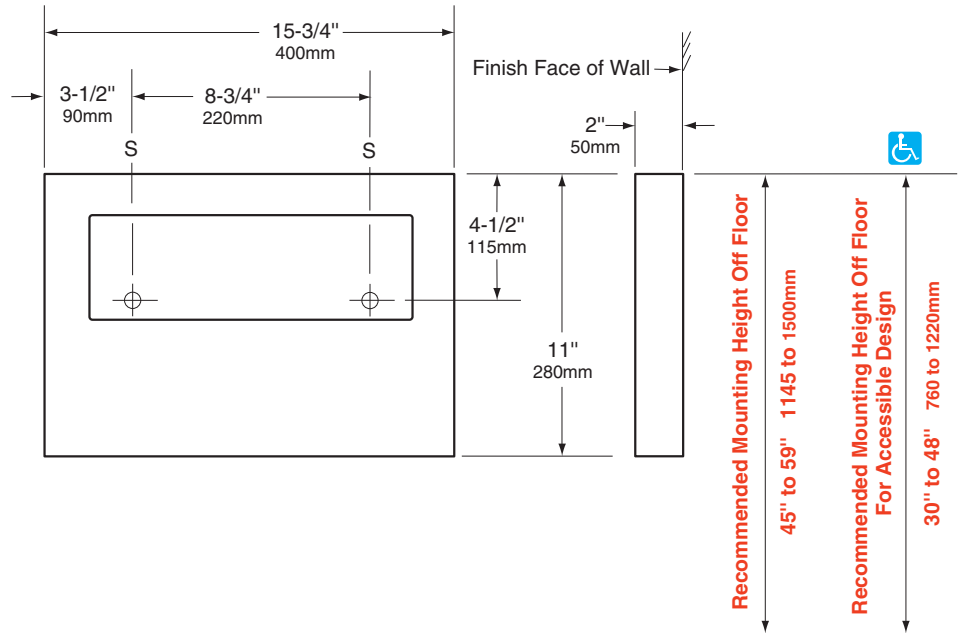

MATERIALS:

18-8, type-304, 22-gauge (0.8mm) stainless steel with satin finish. All-welded construction with beveled opening.

OPERATION:

Dispenses single- or half-fold paper toilet seat covers from beveled opening. Dispenser fills from bottom through concealed opening. Capacity: 500 toilet seat covers.

INSTALLATION:

Mount unit on wall or toilet partition with two flat-head screws, not furnished by manufacturer, at points indicated by an S. For plaster or dry wall construction, provide concealed backing that complies with local building codes, then secure unit with flat-head screws not furnished. For other wall surfaces, provide fiber plugs or expansion shields for use with screws, not furnished, or provide 1/8" (3mm) toggle bolts or expansion bolts.

Note: Provide a 5" (125mm) minimum clearance from bottom of dispenser to top of any horizontal projection to provide room for filling dispenser from bottom.

SPECIFICATION:

Surface-mounted toilet-seat-cover dispenser shall be type-304, 22-gauge (0.8mm) stainless steel with all-welded construction; exposed surfaces shall have satin finish. Dispenser shall have a concealed opening in bottom for filling. Capacity shall be 500 paper toilet seat covers.

Surface-Mounted Seat-Cover Dispenser shall be Model B-221 of Bobrick Washroom Equipment, Inc., Clifton Park, New York; Jackson, Tennessee; Los Angeles, California; Bobrick Washroom Equipment Company, Scarborough, Ontario; Bobrick Washroom Equipment Pty. Ltd., Australia; and Bobrick Washroom Equipment Limited, United Kingdom.

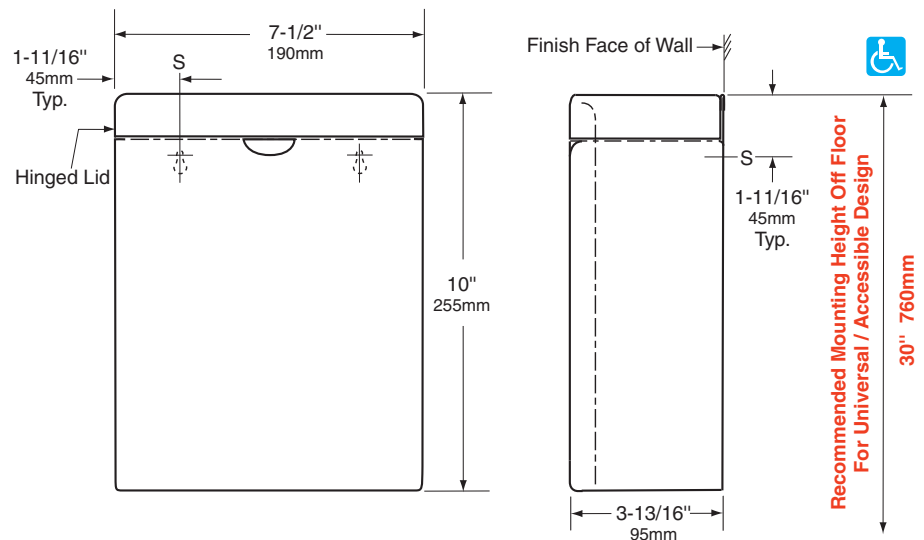

MATERIALS:

Container — 18-8, type-304, 22-gauge (0.8mm) stainless steel. All-welded construction. Exposed surfaces have satin finish. Integral finger depression for opening cover. Front of container has same degree of arc as front of cover and other Bobrick ConturaSeries washroom accessories. Radius on side edges of container match corners and edges of cover and other ConturaSeries accessories.

Cover — 18-8, type-304, 22-gauge (0.8mm) stainless steel with satin finish. Drawn, one-piece, seamless construction. Front of cover has same degree of arc as front of container and other Bobrick Contura Series washroom accessories. Radius on corners and edges of cover match side edges of container and other Contura Series accessories. Secured to container with a full-length stainless steel piano-hinge.

OPERATION:

Cover flips up for disposal of sanitary napkins and for servicing container.

INSTALLATION:

For partitions with particle-board or other solid core, secure with two #8 x 3/4" (4.2 x 19mm) sheet-metal screws (not furnished) at all points indicated by an S, or provide through-bolts, nuts, and washers.

For hollow-core metal partitions, provide solid backing into which sheet-metal screws can be secured. If two units are installed back-to-back, then provide threaded sleeves and machine screws for the full thickness of partition.

For masonry walls, provide fiber plugs or expansion shields for use with sheet-metal screws, or provide 3/16" (5mm) toggle bolts or expansion bolts.

For plaster or dry wall construction, provide concealed backing to comply with local building codes, then secure unit with sheet-metal screws.

SPECIFICATION:

Surface-mounted sanitary napkin disposal shall be type-304 stainless steel with all-welded construction; exposed surfaces shall have satin finish. Front of sanitary napkin disposal shall have same degree of arc and match other Bobrick ConturaSeries accessories in the washroom. Radius on corners and edges of sanitary napkin disposal shall complement other Bobrick ConturaSeries washroom accessories. Cover shall be drawn, one-piece, seamless construction and secured to container with a full-length stainless steel piano-hinge. Container shall have integral finger depression for opening cover.

Surface-Mounted Sanitary Napkin Disposal shall be Model B-270 of Bobrick Washroom Equipment, Inc., Clifton Park, New York; Jackson, Tennessee; Los Angeles, California; Bobrick Washroom Equipment Company, Scarborough, Ontario; Bobrick Washroom Equipment Pty. Ltd., Australia; and Bobrick Washroom Equipment Limited, United Kingdom.